

pöllö   
**Prime Series**



**5MP FHD Motorized Camera**

**PLC-325M-MZ-IR8/PM**

[www.pollo.net.au](http://www.pollo.net.au)

[info@pollo.net.au](mailto:info@pollo.net.au)

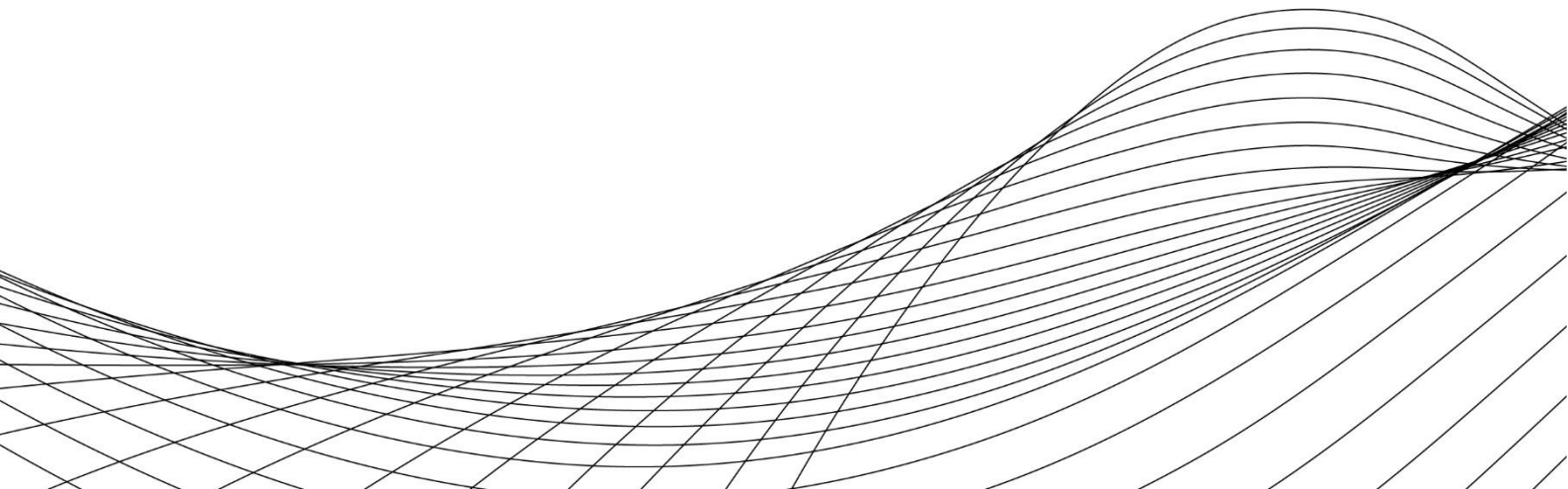
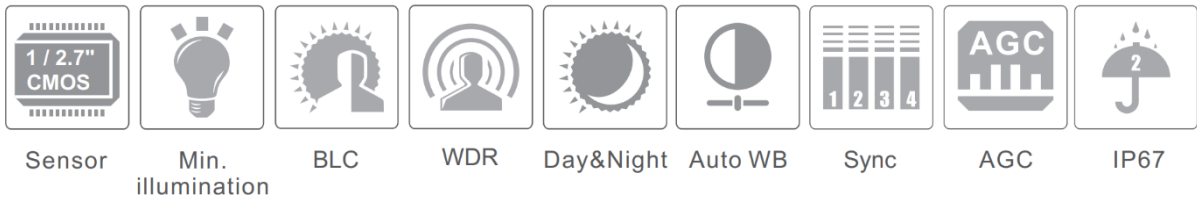



## Key Features:

- ✔ 5MP@20fps/4MP@30fps image, high resolution, true color
- ✔ AHD / TVI / CVI/CVBS standard and lossless video output
- ✔ Up to 1500 TVL resolution
- ✔ CMOS progressive scan, perfectly capture the moving object
- ✔ Support OSD menu
- ✔ High speed, long distance and real time transmission
- ✔ Auto color to B / W at low illumination
- ✔ Support ICR switch, true day / night, WDR
- ✔ Support noise reduction function
- ✔ 50 ~ 70m IR night view distance
- ✔ IP67 ingress protection

## Dimensions:

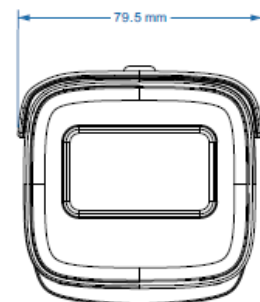
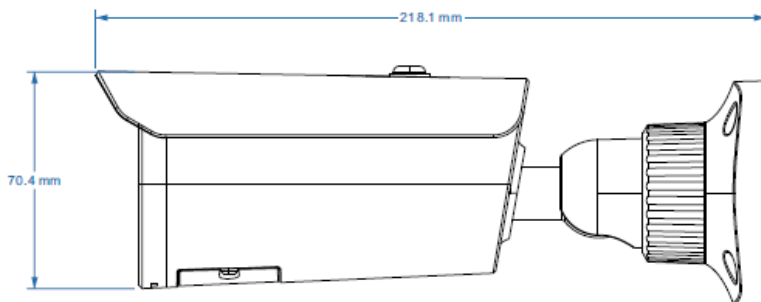

## Specifications:



<b>Model</b>	<b>PLC-325M-MZ-IR8/PM</b>
<b>Image Sensor</b>	1 / 2.7" CMOS
<b>Resolution</b>	5MP
<b>Image Size</b>	2560 x 1936
<b>Video Output</b>	AHD / TVI /CVI/CVBS
<b>Image System</b>	PAL / NTSC
<b>Electronic Shutter</b>	Auto
<b>IR Distance</b>	50 ~80 m
<b>Frame Rate</b>	5MP @20fps
<b>Min. Illumination</b>	Color : 0.01 lux@F1.2, AGC ON; B/W : 0 lux with IR
<b>Lens</b>	2.8~12mm, motorized zoom lens
<b>Lens Mount</b>	D14
<b>S / N Ratio</b>	≥52dB (AGC OFF)
<b>Ingress Protection</b>	IP67
<b>Function Control</b>	OSD (COC Control)
<b>Day &amp; Night</b>	ICR
<b>Digital WDR</b>	Yes
<b>Digital NR</b>	Yes
<b>AGC</b>	Yes
<b>Auto White Balance</b>	Yes
<b>BLC</b>	Yes
<b>LSC</b>	Yes
<b>Defog</b>	No
<b>HLC</b>	Yes
<b>Sharpness</b>	Yes
<b>Mirror</b>	Yes
<b>Smart IR</b>	Yes
<b>Image Setting</b>	Yes
<b>Defect Correction</b>	Yes
<b>Language</b>	13 languages
<b>Angle Adjustment</b>	Pan: 0°~360°; Tilt: 0°~90°; Rotation: 0°~360°
<b>Power Supply</b>	DC12V (± 10%)
<b>Power Consumption</b>	IR OFF: < 1W; IR ON: < 9W
<b>Working Environment</b>	- 30 °C ~ 50 °C, 10 % ~ 90 % (humidity)
<b>Dimensions (mm)</b>	279.5 × 100.3 × 88.9
<b>Weight (net)</b>	Approx. 1.0KG