



5 Megapixel IR FHD Bullet Camera

PLC-325P-IR2/PM

www.pollo.net.au

info@pollo.net.au

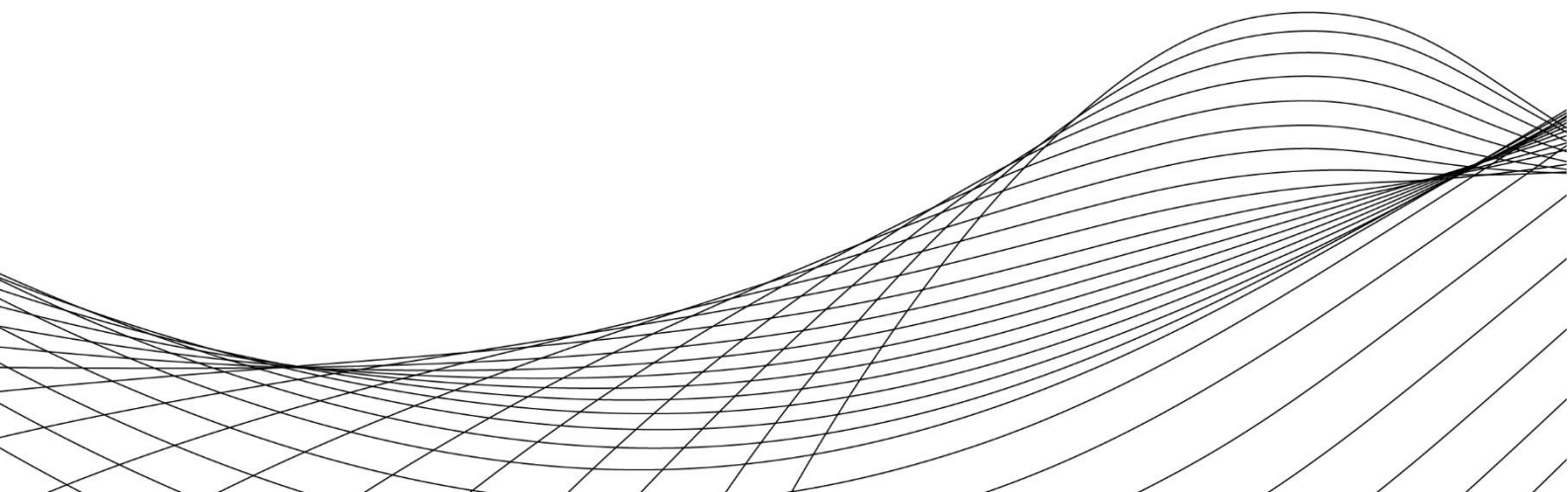
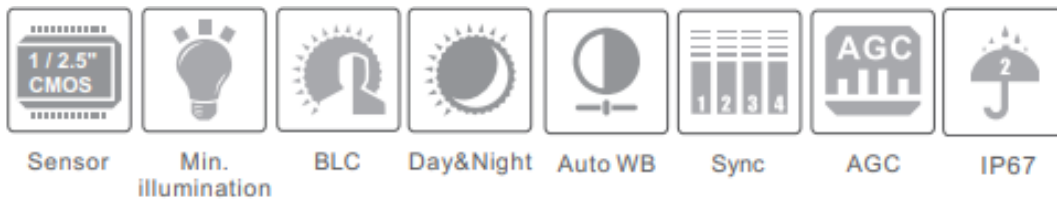

Key Features:

- ✔ 1 / 2.5" CMOS Sensor Progressive Scan
- ✔ 2560 x 1936 Pixels Super HD+2K Resolution
- ✔ 0.01 Lux Min. Illumination for Day Time Color View
- ✔ 30-to-40-meter IR Night View Range
- ✔ Smart Auto Switching to Night View Mode
- ✔ Digital Noise Reduction
- ✔ Digital Wide Dynamic Range
- ✔ Backlight Compensation for Image Correction
- ✔ AHD / TVI / CVI / CVBS Standard Video Output
- ✔ Support OSD Menu
- ✔ IP67 Waterproofing & Dust Proofing
- ✔ DC12V (±10%) Power Supply



Dimensions:

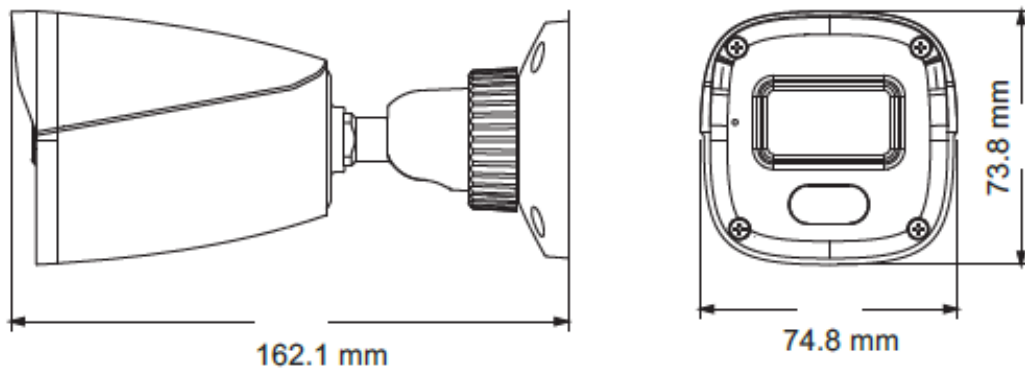

Specifications:

Model	PLC-325P-IR2/PM
Image Sensor	1 / 2.5 "CMOS Sensor Progressive Scan
Resolution	5MP
Image Size	2560 x 1936
Video Output	AHD / TVI /CVI/CVBS
Image System	PAL / NTSC
Electronic Shutter	Auto
IR Distance	30 ~40 m
Frame Rate	5MP@20fps/4MP@30fps
Min. Illumination	Colour: 0.01lux@F1.2, AGC ON; B/W: 0 lux with IR
Lens	3.6 mm
Lens Mount	M12
S / N Ratio	≥52dB (AGC OFF)
Ingress Protection	IP 67
Function	Control OSD (COC Control)
Day & Night	ICR
Digital WDR	Yes
Digital NR	Yes, 2D DNR
Global Exposure	Yes
AGC	Yes
Auto White Balance	Yes
BLC	Yes
Sharpness	Yes
Mirror	Yes
Smart IR	Yes
Image Setting	Yes
Defect Correction	Auto
Language	Chinese and English
Angle Adjustment	Pan: 0°~360°; Tilt: 0°~80°; Rotation: 0°~360°
Power Supply	DC12V (± 15%)
Power Consumption	IR OFF: < 1W; IR ON: < 3W
Working Environment	- 10 °C ~ 40 °C, 10 % ~ 90 % (relative humidity)
Dimensions (mm)	162.1x 74. 8 x 73.8
Weight (net)	Approx. 0.30KG