

pöllö   
**Prime Series**



**5MP FHD Camera**

**PLC-325P-IR2/PM**

[www.pollo.net.au](http://www.pollo.net.au)

[info@pollo.net.au](mailto:info@pollo.net.au)

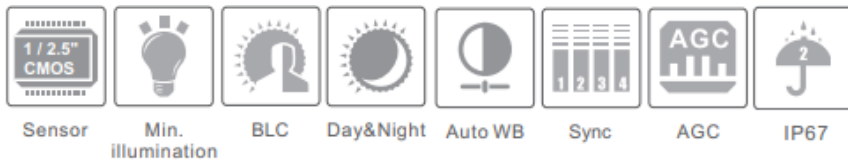

## Key Features:

- ✔ 5MP 20fps/4MP real-time image, high resolution, true colour.
- ✔ AHD / TVI / CVI / CVBS standard and lossless video output.
- ✔ CMOS progressive scan, perfectly capture the moving object.
- ✔ Support OSD menu.
- ✔ High speed, long distance and real time transmission.
- ✔ Auto colour to B / W at low illumination.
- ✔ Support ICR switch, true day / night, digital WDR.
- ✔ Support noise reduction function.
- ✔ 10 ~ 20m IR night view distance.
- ✔ IP67 ingress protection.
- ✔ Support COC.



## Dimensions:

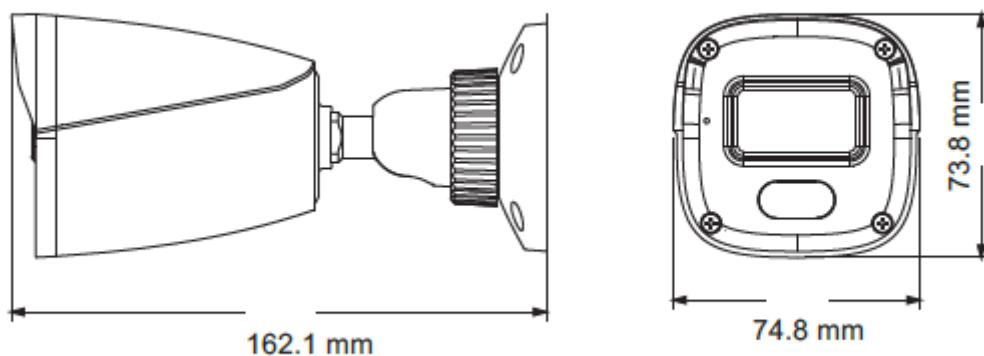

## Specifications:



<b>Model</b>	<b>PLC-325P-IR2/PM</b>
<b>Image Sensor</b>	1 / 2.5" CMOS
<b>Resolution</b>	5MP
<b>Image Size</b>	2560 x 1936
<b>Video Output</b>	AHD / TVI /CVI/CVBS
<b>Image System</b>	PAL / NTSC
<b>Electronic Shutter</b>	Auto
<b>IR Distance</b>	10 ~20 m
<b>Frame Rate</b>	5MP@20fps/4MP@30fps
<b>Min. Illumination</b>	Colour: 0.01lux@F1.2, AGC ON; B/W: 0 lux with IR
<b>Lens</b>	3.6 mm
<b>Lens Mount</b>	M12
<b>S / N Ratio</b>	≥52dB (AGC OFF)
<b>Ingress Protection</b>	IP67
<b>Function</b>	Control OSD (COC Control)
<b>Day &amp; Night</b>	ICR
<b>Digital WDR</b>	Yes
<b>Digital NR</b>	Yes, 2D DNR
<b>Global Exposure</b>	Yes
<b>AGC</b>	Yes
<b>Auto White Balance</b>	Yes
<b>BLC</b>	Yes
<b>Sharpness</b>	Yes
<b>Mirror</b>	Yes
<b>Smart IR</b>	Yes
<b>Image Setting</b>	Yes
<b>Defect Correction</b>	Auto
<b>Language</b>	Chinese and English
<b>Angle Adjustment</b>	Pan: 0°~360°; Tilt: 0°~80°; Rotation: 0°~360°
<b>Power Supply</b>	DC12V (± 15%)
<b>Power Consumption</b>	IR OFF: < 1W; IR ON: < 3W
<b>Working Environment</b>	- 10 °C ~ 40 °C, 10 % ~ 90 % (relative humidity)
<b>Dimensions (mm)</b>	162.1x 74. 8 x 73.8
<b>Weight (net)</b>	Approx. 0.30KG